

NOTICE - SOURCE FLUID POWER CLAIMS PROPRIETARY RIGHTS ON THE INFORMATION DISCLOSED ON THIS DRAWING. IT IS ISSUED IN CONFIDENCE FOR ENGINEERING INFORMATION ONLY AND MAY NOT BE REPRODUCED OR USED TO MANUFACTURE ANYTHING HEREON WITHOUT DIRECT WRITTEN PERMISSION FROM SOURCE FLUID POWER TO THE USER.



SOURCE FLUID POWER

331 Lake Hazeltine Drive
Chaska, MN 55318
952-368-3866 (Fax) 952-448-3392

Manual Over-ride: SFP Motorized Flow Control Valves Part Numbers: F 10 ** ** and F 16 ** **

NOTE: Valve adjusts through full range in 90° rotation.
Procedure:

1. Loosen SHCS on lock collar using 3/16 " hex wrench.
2. Grab the motor can with your hand and turn the can clockwise to the desired flow setting.
If the desired flow setting can not be reached then turn the can counter clockwise to flow setting.
3. Tighten lock collar to hold position.
4. If further adjustments are necessary repeat steps 1 through 3 as required.
5. Retine valve after manual adjustment before returning to 12 VDC operation. See separate instructions.

**** Never turn more than a total of 1 turn counter clockwise ****
as motor assembly may separate from hydraulic cartridge causing leaks or potential injury.

Grip & Turn Motor Housing for Manual Over-ride.

Loosen SHCS for Manual Over-ride (3/16 hex wrench)
Warning: Valve must be re-timed before returning to 12 VDC operation.



Instructions for timing a Source Fluid Power motorized flow control valve (F10**** or F16****)

If the lock collar has been unclamped and the motor drive assembly rotated to manually adjust the valve or the valve has been disassembled for seal kit installation, the valve must be "retimed" to align the motor drive limit switches with the cartridge metering slots before operating with 12/24 VDC. The cartridge must be removed from the manifold. If the seals have been replaced follow steps 1 through 8. If only the manual over-ride has been used, skip to step 4.

- 1) Check assembly of the metering spool stem. The order of parts should be thrust washer, thrust bearing, thrust washer and 2-011 poly o'ring.
- 2) Hold the motor assembly with the cable down. Find the slotted recess in the face of the motor housing near the SAE #10 male boss. Place the lock collar over the SAE boss so alignment pin engages slotted recess.
- 3) Looking inside the end of the motor housing note the orientation of the drive slot. Insert the drive tang end of the metering spool assembly into the SAE boss. Rotate the metering spool while maintaining steady pressure pushing the spool into the valve. The drive tang will engage the slot and the metering spool will push into the motor housing until the thrust washer rests against the SAE boss. The o'ring should slip into the counter bore in the nose of the SAE boss.
- 4) With the SHCS on the lock collar loose thread the hydraulic cartridge end of the valve assembly onto the motor can assembly until it bottoms out on the motor housing.
- 5) Connect 12/24 VDC to the black wire and ground to the white wire lead. The motor will turn until the full open limit switch is open. The motor drive is now positioned in the "full open" position.
- 6) Looking at the hydraulic end of the assembly examine the alignment of the metering slot in the cartridge body to the metering hole in the metering spool. Turn the cartridge body CCW as required to align the spool's metering hole in the cartridge metering slot. In the full open position the drilled hole in the spool will completely open the metering slot in the cartridge body.
- 7) Tighten the SHCS on the lock collar using a 3/16" hex wrench. Make sure the lock collar alignment pin has engaged the slot on the motor housing and that the lock collar is flush against the motor housing. Test the timing by reversing polarity on the 12 VDC leads while observing whether the valve fully opens and closes. Adjust as required.
- 8) Reassemble into manifold and torque to 35 ft-lbs. for F10**** valves and 65 ft-lbs. for F16**** valves. Torque only the hex on the cartridge body, do not grip the motor housing or lock collar.

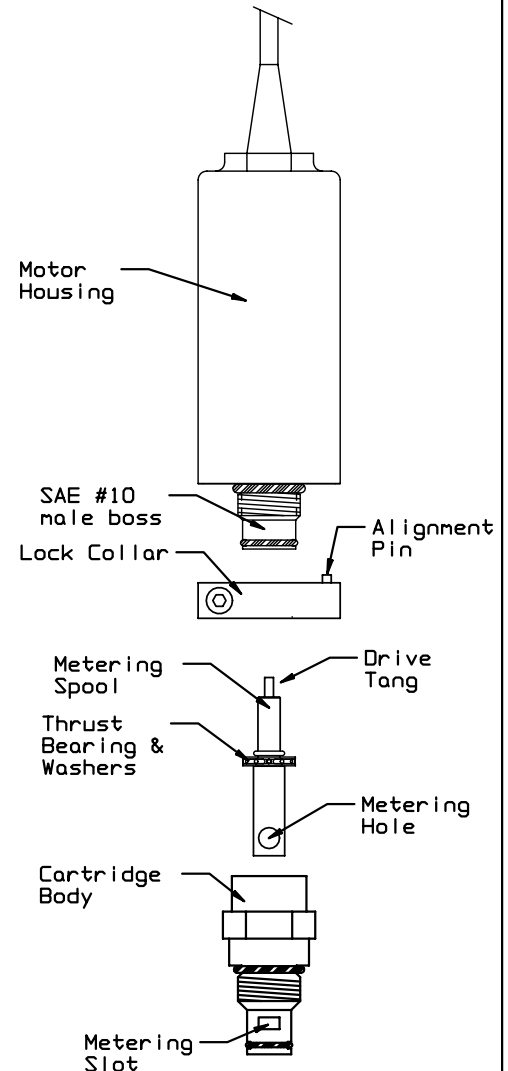

TITLE

25200MtrTiming.prt

01/05/08

Part Numbers Affected

Motorized Flow Control: Manual Over-ride and Valve Timing

F10** ** / F16** **